



SAILRITE

Est. 1969

# MAKE YOUR OWN SERIES DROGUE

Drogue Kit Instructions downloadable #861310





# Table of Contents

Overview	2
Cone Construction	3
Line Preparation	5
Cone Attachment	6
Bridle Attachment	8
Drogue Deployment	8
Drogue Retrieval	8
Structural Requirements	9
Final Thoughts from Don Jordan	10

## Overview

The new Series Drogue, as conceived by Don Jordan, was designed in collaboration with U.S. Coast Guard researchers after tests showed conventional sea anchors were subject to fatigue failure as the single large fabric parachute would fill with water and then collapse under the strains of storm waves.

The Series Drogue looks like a parade of jellyfish in single file, but is really 100 or more 5" diameter nylon sailcloth cones attached every 20 inches along a long rope. The design ensures the cones will fill and grab hold of water keeping the boat properly positioned for the next wave strike (best capsizing prevention for breaking waves). Proper boat position is "stern to" or running with oncoming waves, lessening the relative speed of the on-rushing walls of water.

This new design is steadier and ensures that boat fittings are under a more-constant load and less likely to get destroyed. In simulated fatigue testing, the drogue was subjected to 15,000 cycles (the equivalent of a giant hurricane) without a failure. A 15–50 lb anchor attached to the end of the line keeps the drogue from popping out of the water, a common problem with conventional sea anchors.

Deployment and retrieval from the water is easy and in most cases can be done hand-over-hand. A winch can be used for retrieval in extremely difficult storm conditions (drogues can compress around winch without damage).

The U.S. Coast Guard development team hopes that boaters will add this easily made and stored device to their boat's inventory of safety equipment.

## Coast Guard Recommendations

**Line Diameter:** Line size may be decreased near the end of the drogue due to diminishing stress. If more than one size is used, make each section equal in length.

**Bridle Specifications:** Make from 3-strand line, double-braided line, or wire. Each bridle leg should be: 2.5 x Transom Width + 2 ft. (allowance for splicing and attachment to boat). Often the bridle is a different color so it can be located quickly. Line for bridle should match the strength of the largest line used in the drogue.

**Anchor Specifications:** Use lead shot, chain, or scuba weights in lieu of traditional mushroom anchors. See anchor weight recommendations in chart.

\*Complete USCG Series Drogue Findings & Recommendations available online under any Sailrite drogue kit or call The National Technical Information Service, US Dept. of Commerce (1-888-584-8332) to request Document #ADA 188 598. Cost: \$48.00.

## Specifications Based on Coast Guard Recommendations

MONOHULL				
DISPLACEMENT	CONE #	LINE LENGTH*	LINE DIAMETER	ANCHOR WEIGHT
N/A	10	-	-	-
10,000 lb.	100	246 ft.	5/8"	15 lb.
15,000 lb.	107	258 ft.	5/8"	15 lb.
20,000 lb.	116	139 / 139 ft.	3/4", 5/8"	15 lb.
25,000 lb.	124	145 / 146 ft.	3/4", 5/8"	25 lb.
30,000 lb.	132	152 / 152 ft.	3/4", 5/8"	25 lb.
35,000 lb.	139	157 / 158 ft.	3/4", 5/8"	25 lb.
40,000 lb.	147	111 / 111 / 112 ft.	1", 3/4", 5/8"	30 lb.
45,000 lb.	156	116 / 116 / 117 ft.	1", 3/4", 5/8"	40 lb.
50,000 lb.	164	121 / 121 / 121 ft.	1", 3/4", 5/8"	50 lb.

MULTIHULL				
DISPLACEMENT	CONE #	LINE LENGTH*	LINE DIAMETER	ANCHOR WEIGHT
6,000 lb.	130	296 ft.	5/8"	15 lb.
12,000 lb.	140	312 ft.	5/8"	15 lb.
18,000 lb.	150	167 / 167 ft.	3/4", 5/8"	15 lb.

\*Line length includes 75 ft. lead line. Bridle line is not included in chart. Lines are not pre-spliced.

# 1 | Cone Construction

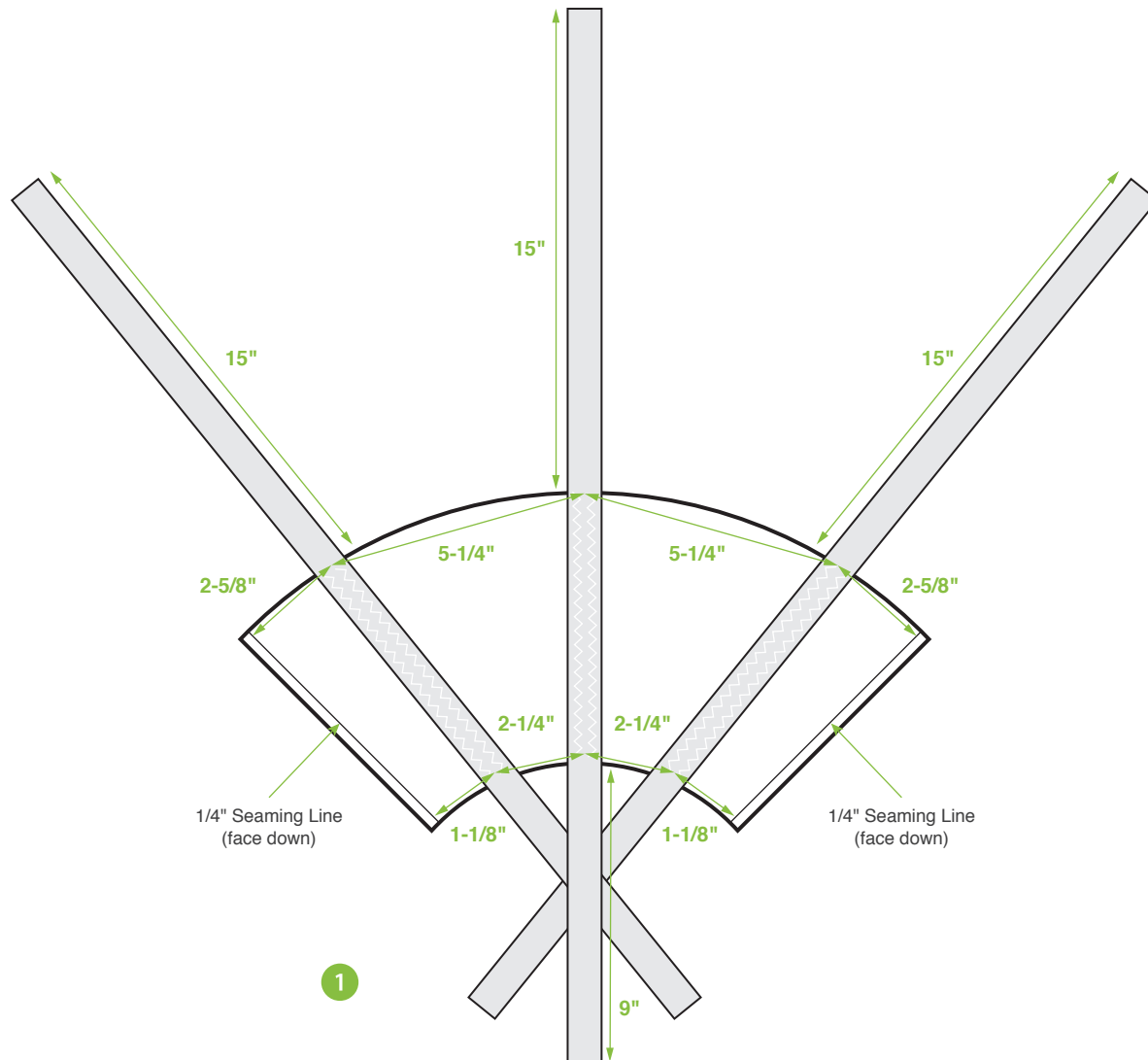

## Attaching the Straps

Sew 3 strips of 30" long strapping to the precut cones (included in the kit). First, lay the cone flat (seaming lines face down). Using the measurements in **Figure 1**, position the straps on the cone. There are also marks on each cone to indicate the center of each strap. Straps should extend 15 inches beyond the wide end of the cone and 9 inches beyond the smaller end. Once positioned, attach the straps to the cone with double sided basting tape. Sew along both edges of the strap using a 1/4" wide zigzag stitch or medium length straight stitch. Reverse the sewing machine at the beginning and end of each pass to lock the stitching.

2

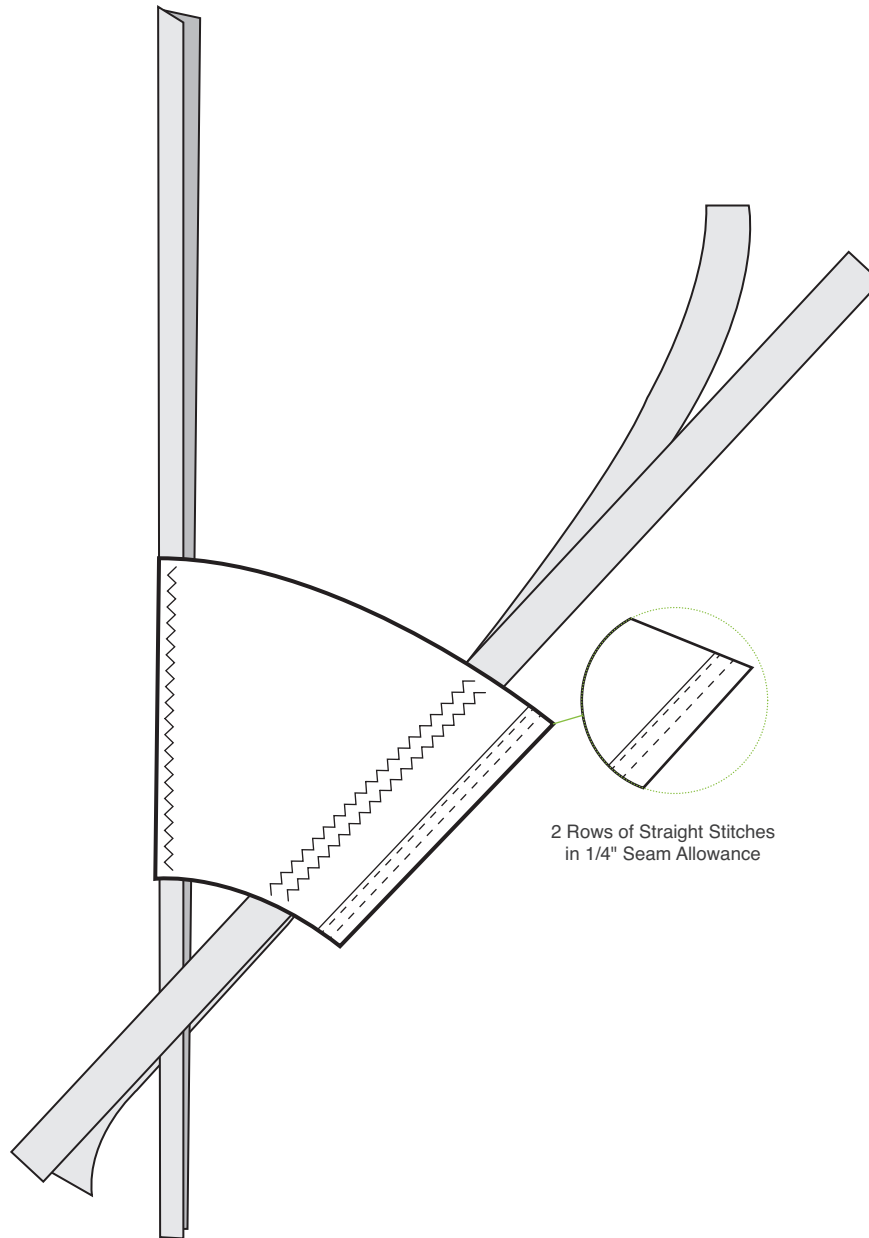

2 Rows of Straight Stitches  
in 1/4" Seam Allowance

### Assembling the Cones

Sew the cone assembly together to form a tube. The seaming lines should be facing out and the sewn straps facing in. Align the straight edges of the cone. Use 1/4" basting tape, if needed, to hold the edges together for sewing. Sew two rows of straight stitches, one on the marked seaming line and the other along the outer edge **Figure 2**. Remember to reverse the stitches at the beginning and end of each run.

Repeat these steps for all cones. Turn the cone assemblies rightside out when done so the straps are on the outside.

## 2 | Line Preparation

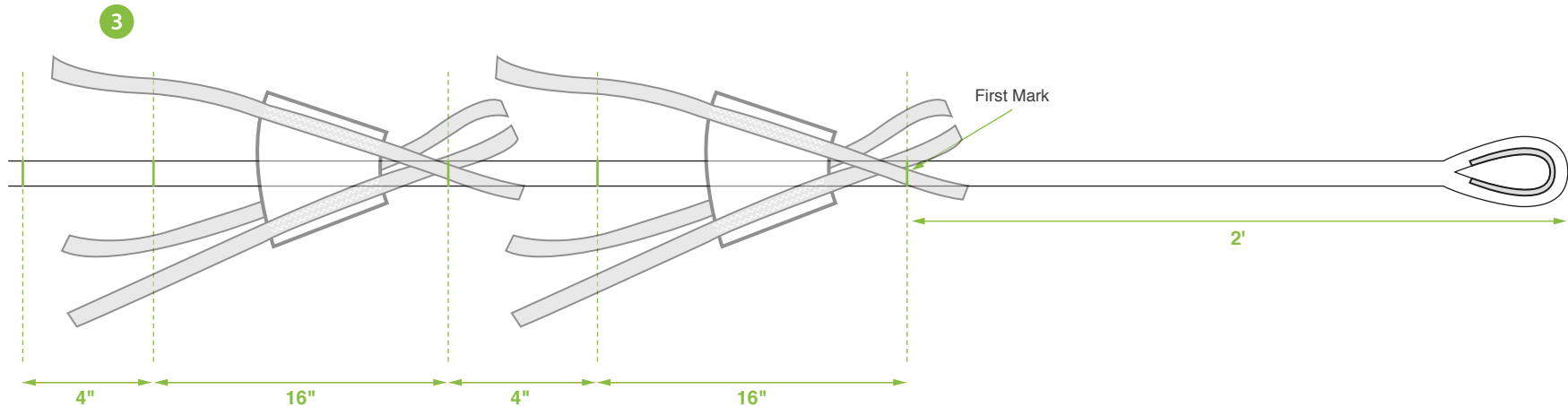

### Line Size & Length

One or more sections of line are used to create the drogue. In order to reduce the size and weight of the finished drogue, decrease the line diameter toward the tail end of the drogue where there is less stress. Follow the Coast Guard's recommendations for line size (p. 2) or use the largest line recommended for everything.

The first 75 feet of line is called the lead line and no cones are attached to this section. The actual length of the lead line will vary due to length of eye splices and how the cones are arranged around them. The length of the lead line is not that critical so long as the first cone is far enough away from the boat to stay submerged. The remainder of the line is used for cone attachment.

### Getting Started

Cut the lines to the lengths specified in the chart for the boat's displacement range. Next, install a thimble on one end of the smallest line. The thimble is used to attach the anchor to the drogue line (one of several anchor attachment methods). All other line ends need to have eye splices with approximately 8" openings for attaching the lines together and attaching the lead line to the bridle.

Sailrite recommends using Brion Toss's Splicing Wands to install the thimble and to make eye splices. Follow the simple eye splice instructions enclosed with the splicing tool.

Pre-marking the line makes for quicker cone attachment. Stretch the line out on a flat surface under moderate tension. Start with the smallest diameter line at the thimble end.

Using a felt tip pen, make the first mark 2 feet from the thimble end. Continue placing marks at 16 inch and 4 inch intervals **Figure 3**. Cones will be positioned between the 16" marks. Avoid placing any marks over the eye splices (cones will not be attached to the splices). Also, do not be concerned if the marks do not end at an even interval.

Follow the same procedure if the drogue is made of more than one line diameter except start the first cone mark just after the eye splice. Remember that approximately 75' of line at the forward end (lead line) does not require marks.

# 3 | Cone Attachment

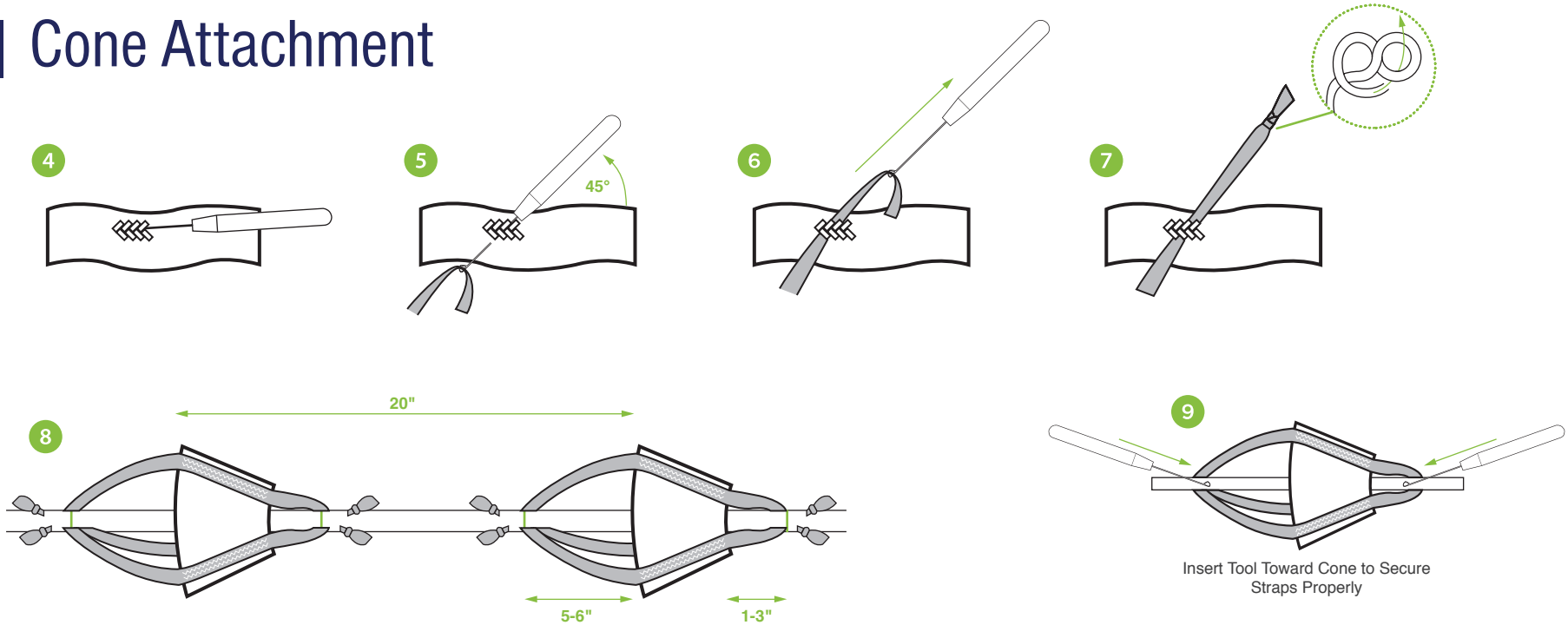

## About Cone Attachment

The cone attachment process is tedious but does not require any special skills. The location of each cone is not critical, and tests have shown that the cones will not pull out of the braid. On average it should take about 4 minutes to install one cone. Allow 2 to 3 days of reasonable effort to install 100 cones.

## Positioning the Cones

Slide all cones onto the line. It may be easier to move groups of cones to their approximate location. All cones should face the same direction with the small end of each cone closest to the trailing end of each line. Position each cone in between the 16 inch marks. This will result in mouth-to-mouth cone spacing of approximately 20 inches.

## Attaching the Cones

Attach the cone straps to the line using a latch hook. Start with the straps at the small end of the cone first. Insert the end of the tool along the axis of the line so that it is angled toward the cone **Figure 4** and pass under about 4 to 6 strands of the outer braid only. (Note that it is not necessary or desirable to pass the strap through both the inner and outer core of the line.) Move the tool until you can feel it cleanly under the outer braid, then rotate the tool to 45 degrees to the axis of the line and push it out through the braid **Figure 5**.

Insert the strap into the hook and pull the strap through the braid **Figure 6**. Tie a "Figure 8" knot in the end of the strap at the small end of the cone to finish **Figure 7**.

Attach the other two straps so that the rope is divided into thirds (rotate the line by a third and insert the next strap). There should be 1–3 inches between the knots and the small end of the cone **Figure 8**.

Repeat these same steps for the straps at the large end of the cone. Remember to insert the tool towards the cone end **Figure 9**. Due to stresses on the straps at the large end of the cone, it is recommended to tie an "Overhand Knot" over the "Figure 8" knot to ensure the straps will not pull through the braid. There should be about 2–3 inches of slack in the straps at the large end of the cone so the mouth of the cone can fully open underwater when the drogue line is taut **Figure 8**.

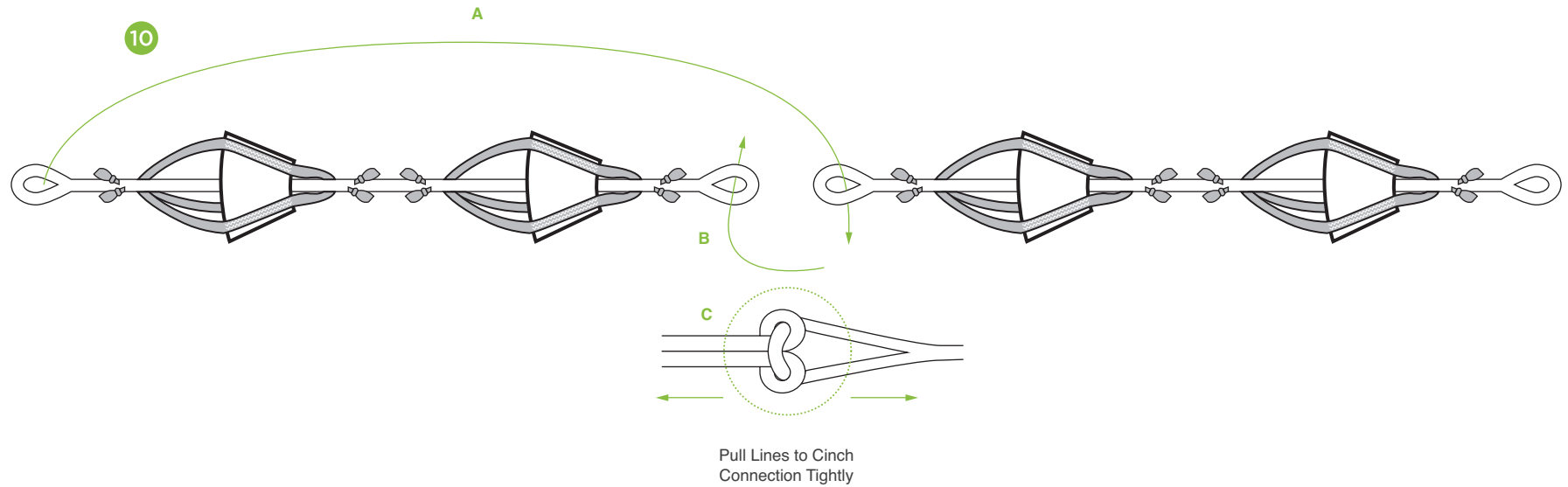

### Joining the Line Sections

After all the cones are attached, join the sections of line together by passing the forward end of the first line (line that will attach to bridle) through the forward eye end of the second line and then through the trailing eye end of the first line. Snug the lines to cinch the connection tightly **Figure 10**. Remember that the larger diameter lines are followed by the smaller diameter lines. The cones should all face the same direction with the large mouth of each cone forward. Attach the two bridle legs the same way **Figure 11**.

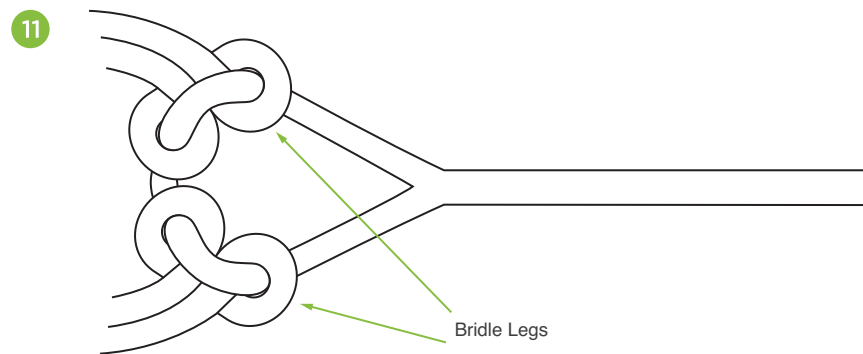



### Completed Series Drogue

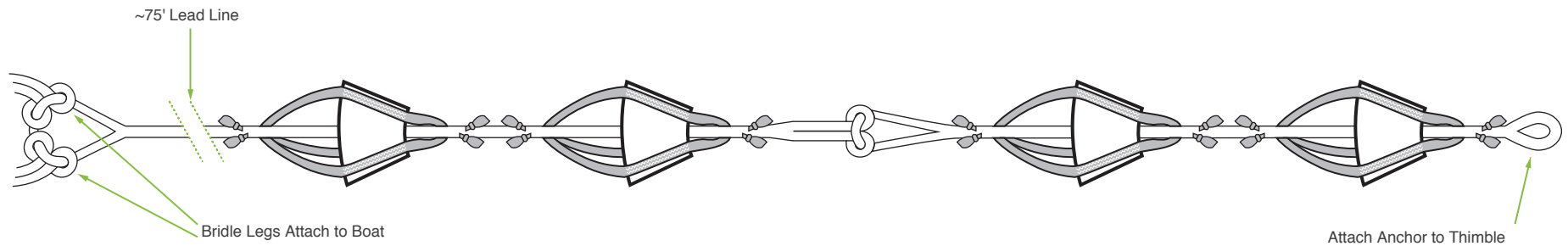

## 4 | Bridle Attachment

The bridle attachment point is critical to the safety and effectiveness of the series drogue.

### ATTACH TO:

- Furthest aft and outboard corners of a monohull.
- Furthest aft or forward and outboard corners of a catamaran or trimaran.
- Fitting of adequate strength with a secondary attachment to distribute the load to the hull structure.

Attach the bridle so as to reduce chafe (do not use fairleads unless absolutely necessary). Be sure that the cockpit area and its hatches/doors can withstand a water jet velocity of 15 ft/sec.

## 5 | Drogue Deployment

Attach the bridle to the boat and make sure it is not twisted. Next, attach the anchor to the drogue end. Using a lazarette or secured drogue deployment bag, slip the anchor overboard to pay out the drogue.

Once the drogue is set, the cones will fill and begin to produce a drag. Steerage will be lost so the rudder should be locked amidship. Crew and helmsman should go below.

## 6 | Drogue Retrieval

Retrieve the series drogue hand-over-hand. The load will be significantly less than the working load during a storm. Further reduction of the load can be achieved by heading into the seas so that the drogue's velocity relative to the water is zero.

In extreme cases, use a winch for retrieval. The drogue will compress around the winch without damage to its integrity.

12

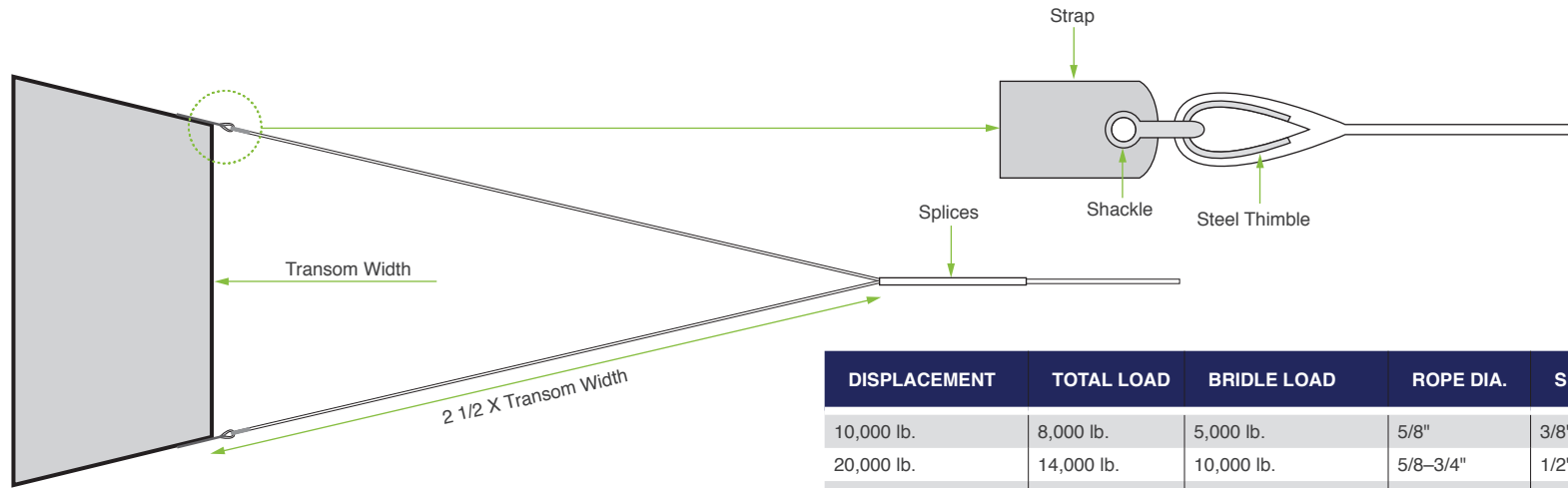

DISPLACEMENT	TOTAL LOAD	BRIDLE LOAD	ROPE DIA.	SHACKLE SIZE
10,000 lb.	8,000 lb.	5,000 lb.	5/8"	3/8"
20,000 lb.	14,000 lb.	10,000 lb.	5/8-3/4"	1/2"
30,000 lb.	20,000 lb.	14,000 lb.	3/4"	5/8"
40,000 lb.	25,000 lb.	17,500 lb.	7/8"	3/4"
50,000 lb.	30,000 lb.	21,000 lb.	7/8"	3/4"

## 7 | Structural Requirements

### A Note From Don Jordan

I am sending this note to all purchasers of the series drogue. I want to make sure that you all have a clear understanding of the loads that the drogue may impose on the boat at the attachment points.

Several boats have ridden out severe storms including one hurricane with the drogue deployed. The drogue performed as it should. The crews reported that they did not feel threatened and the drogue loads appeared to be moderate. However, none of the boats were struck by a dangerous breaking wave such that capsized the yachts in the Fastnet storm or the recent New Zealand storm. On some of the boats which used a series drogue the bridle was led through a chock and belayed on a sheet winch. This arrangement is suitable for non breaking waves but it may not be adequate for a dangerous breaking wave.

For a boat displacing 30,000 lb., model tests and computer simulation predict that the drogue can generate a force approaching 20,000 lb. when struck by a very powerful (and fortunately extremely rare) breaking wave. The tests also show that when the boat is struck on the quarter, one leg of the bridle will be subjected to 70% or 14,000 lb. Thus the attachment point should have the capability of carrying a once in a lifetime load of this magnitude.

I have no information on the ultimate strength of a typical sheet winch installation and it would be difficult to evaluate each unique mounting. Unfortunately a winch (or a cleat) is not an ideal structure, since the load is applied above the deck line and tends to overturn the winch and tear it out of the deck. The optimum attachment for the drogue is clearly a strap similar to a chain plate, bolted to the hull at the corners of the transom **Figure 12**. This arrangement feeds the load directly into the hull and imposes no bending or pullout loads on the hull or deck. For a load of

14,000 lb. a strap 1/4" x 2-1/4" x 18" attached by 6 - 3/8" bolts would provide a conservative design.

Such a strap is relatively inexpensive and should not be difficult to install. You may never need it but it is prudent policy to insure that the full capability of your series drogue can be achieved.

Miles Smeeton in his book "Once Is Enough", which many of you have probably read, presents one of the best descriptions of the power and unpredictability of a breaking wave. It is this extreme case that the series drogue is developed to handle.

Listed above is a table of design loads for a single bridle attachment. These loads are believed to be the worst case loads with some margin. However, since the loads are determined by the size and shape of the worst wave there remains some uncertainty as is the case with many natural phenomena.

# Final Thoughts

## A Note From Don Jordan

The series drogue was developed to perform two separate functions:

1. To prevent the capsize of monohull and multihull sailboats in the event of a large breaking wave strike.
2. To improve the motion of the boat in storm waves and to reduce drift.

Most storms do not generate dangerous breaking waves. A vessel may go through a lifetime of cruising without being struck by a breaking wave even though hurricane winds have been encountered.

Although storm waves move at speeds up to 30 knots, the water in the waves moves at a much lower speed. A boat lying ahull is not subjected to high forces. Experience and testing have shown that a well found monohull with positive stability at 90 degrees roll angle has little risk of being dragged by non-breaking storm waves. A multihull, however, may be capsized.

A dangerous breaking wave is formed by the interaction of two or more storm waves. This type of wave has a large mass of water at its crest moving at wave speed (20-30 knots). When a vessel lying ahull is struck by this moving mass of water, a very large force is developed. In a typical

event the boat has been successfully riding out the storm for many hours, then, 10 seconds later it lies dismasted and damaged. It is the function of the drogue to turn the stern into this moving mass of water and pull it safely through.

The risk of breaking wave capsize is dependent on the weight of the vessel, with small light boats being at high risk. Above a length of 40' the risk is diminished, and above 60' few, if any, breaking wave capsizes are on record.

On a conventional monohull sailing yacht the underwater lateral surface is located aft of the center of the boat while the topside area is greater towards the bow. When struck by a moving mass of water the bow of such a vessel is driven down by a powerful turning moment. Therefore, it is necessary to use a drogue from the stern rather than a sea anchor from the bow to align the boat with the moving water and pull the boat through.

A multihull is relatively symmetrical fore and aft, although there is still some tendency for the bow to be driven down by the wave. Testing indicates that either a drogue or sea anchor, if properly designed, can be effective in preventing breaking wave capsize. However, the force required of the drogue is less than that required of a sea anchor.

Some sailors have expressed reluctance to use a drogue

for fear of being "pooped". Testing has shown that a conventional monohull or multihull will perform in a safe manner when riding stern to the sea. Actually, the stern generally has more local buoyancy than the bow and will rise quickly to a steep sea. However, storm waves will have whitecaps containing some moving water and this may splash aboard. In a dangerous breaking wave strike, moving water may sweep the cockpit and strike the companionway doors. This is unavoidable, and is a necessary corollary to saving the vessel.

Recovery: The crew of a 40' ketch practiced several methods of taking in the drogue in a Force 7 wind in the English Channel. They concluded that the best system was to grind it in with a cockpit winch a little at a time, letting the sea help you and belaying when the pull was high. With a little care they avoided tearing any cones. Another system is to prepare two helper lines, clamp one line on the drogue and winch in 3 or 4 feet, then repeat with the other line. This takes 20 minutes or so, but is safe and not particularly difficult.

Adding a light line in parallel with the drogue to permit the drogue to be pulled in backwards is definitely not recommended since it complicates the gear and may lead to fouling under critical conditions.

### Don Jordan

Inventor of the Series Drogue